

MODULAR SWITCHED MODE POWER SUPPLIES – A WAY TO SOLVE THE CHALLENGES OF RELIABILITY, OUTPUT PROPERTIES AND COST, COMPARED TO CONVENTIONAL T/R'S IN ESP APPLICATIONS.

ARNE THOMAS HAALAND, FRODE VIK, ARILD NESSE, BJARTE KVINGEDAL, ØYVIND WETTELAND AND HÅVARD VETRUS
Applied Plasma Physics AS (APP), Norway

ABSTRACT

One of the conclusions following the ICESS IX was that switched mode power supplies gradually would gain the dominating position as power sources for industrial ESP's. However, reliability issues, limitation in voltage/power rating and cost competitiveness compared to conventional T/R's have limited the acceptance of this technology in the industry. As a solution to these obstacles, this paper describes a new and innovative design approach by presenting a modular switched mode power supply concept, the APP ModuPower™.

Development of the ModuPower™ concept is based on more than 8 years of experience in development and delivery of switched mode power supplies to industrial plasma applications. It is a true modular concept where output voltage is decided by connecting the high voltage modules in series to the desired level, while output current capacity is decided by connecting modules in parallel. The modular concept is made possible by implementing a novel, patented high voltage transformer design, allowing serial connection of transformers without serious power/efficiency loss. In addition, low parasitics in the transformer, allows simplified switching techniques resulting in simple building blocks for the modular concept.

The modular approach decomposes the challenge of high voltages and high power ratings into manageable entities, while offering output voltages up to 120 kV and in principle, unlimited output power ratings. Furthermore, the modular concept is well suited for implementing redundancy inside the power supply, resulting in a fault tolerant system, and thereby increased reliability. Simple and efficient building blocks in a modular configuration, result in a small and cost competitive power solution compared to conventional power sources.

Through the development of ModuPower™, APP aim at solving the major objections towards using switched mode power supplies in ESP applications, which hopefully moves us closer to the long announced paradigm shift in this industry.

BACKGROUND

Electrostatic precipitators have a long and merited history within air pollution control applications. Line frequency switching transformer/rectifier sets, T/R's, have an equally long history as the "engine" of an ESP. Over the years, this has proved to be a reliable and efficient solution to a wide range of air pollution control applications.

With the introduction of high frequency switch mode technologies to the ESP-world 10-15 years ago, new possibilities were identified (described in several publications of which [1], [2], [3]: increased efficiency of the ESP's, reduced weight and cost, simplified electric infrastructure etc. Since then, switched mode power supplies (SMPS) have gradually gained acceptance in the industry, but from a broad perspective, they are still representing a "young and promising" technology.

The industry seems to agree that switched mode power supplies will gradually gain a dominating position as "ESP-engine", but as pointed out in the concluding words of ICESP-IX, it's hard to know how fast this will happen. One thing is certain: new requirements for higher efficiencies in ESP's and need for increased cost competitiveness, will force changes to happen and the high frequency switched mode power supply technology will be an important element in these changes, especially when focusing on the retrofit market.

The switched mode power supplies that have been introduced to the market over the years have indeed proved this technology to have a great potential. However, some issues are still preventing full industrial acceptance and implementation:

- Limitations in available output voltage ranges
- Limitations in available power ratings
- Short track-record compared with T/R's in combination with some reliability issues in early SMPS versions, have made the industry concerned about the reliability of the SMPS technology in general
- In some cases lack of cost competitiveness compared with T/R's

All these issues have nurtured the industries natural scepticism towards the new technology, which again has slowed down a transition in favour of switched mode power supply technology.

On this background APP set forth to develop a new switch mode power supply concept that responds to the arguments against using this kind of technology in the ESP industry.

COMPARISON OF LINE FREQUENCY V.S. HIGH FREQUENCY POWER SUPPLIES

The fundamentals of the two different approaches to energize ESP's have been described in this forum earlier, such as in [1] and [3]. So only a brief description of the two technologies and the difference between them will be given here, and the consequences of these differences will be discussed.

Transformer/rectifier set – T/R

In traditional transformer/rectifier sets, the line frequency signal is fed into the high voltage transformer and thereafter rectified before supplied to the ESP.

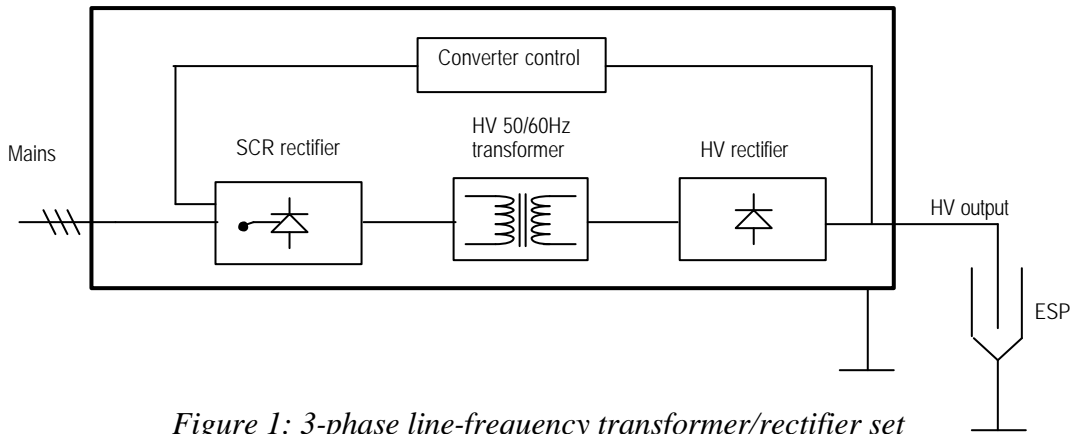

Figure 1: 3-phase line-frequency transformer/rectifier set

If the input line feed is 3 phase 50 Hz, the resulting high voltage signal is a DC superimposed a 300 Hz ripple. This ripple represents one of the main disadvantages with the T/R's. The list below points out some of the disadvantages:

- An ESP will normally be controlled to operate just below the arcing voltage to achieve max. efficiency.
- Actual ESP efficiency is dependant on the average voltage level in the ESP. A high ripple will result in a significantly lower average voltage than the arcing voltage.
- A T/R is large in size and weight and will require special care in plant construction
- A T/R may contain large dielectric volumes requiring special precautions against oil spills.
- Low $\cos \phi$ factor (0,65 - 0,75)
- Low power efficiency factor (0,75 – 0,85)

Even with these significant negative effects, the T/R's have definitely also positive sides

- + Technology well suited for cost efficient re-sizing/scaling
- + Simple and well proven technology
- + Well understood technology by relevant user groups
- + High reliability in practical applications
- + Proven to be cost efficient in many applications

Switch mode power supplies - SMPS

In a switched mode power supply, the line frequency is rectified to a DC before converted to a high frequency AC signal in a power electronic inverter. The AC signal is fed into a high voltage transformer and thereafter rectified before supplied to the ESP.

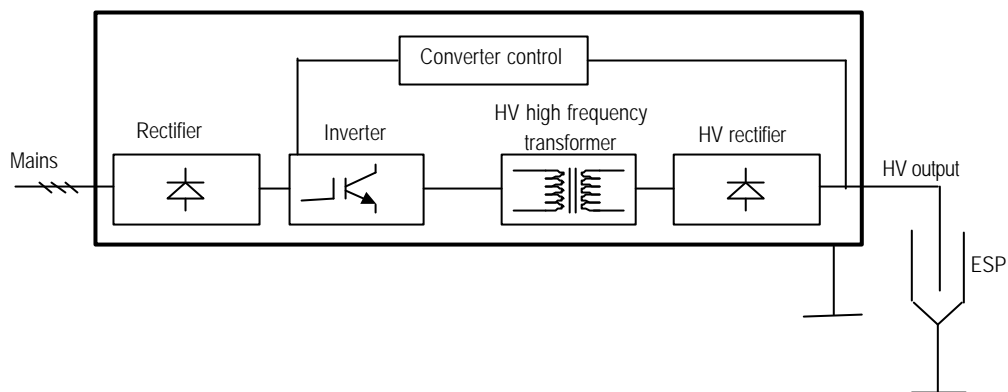

Figure 2: 3-phase high frequency switched mode power supply

The operating frequency of a SMPS will normally be in the area 20-50 kHz resulting in a very low ripple in the rectified signal. The relation between ripple amplitude and frequency is defined by the following equation:

$$U_{\text{ripple}} = I_{\text{ripple}} \frac{1}{2 \pi f C} \quad (1)$$

where "f" is the switching frequency and C is the capacitance in the load connected to the SMPS – in this case the ESP. So, the ripple amplitude is inverse proportional with the switching frequency. Compared with a line frequency 3 phase T/R, feeding a 300 Hz ripple into the ESP, an SMPS with a switching frequency of 30 kHz, feeding a 60 kHz ripple into the ESP, will according to equation (1) have a ripple voltage amplitude 200 times lower. Again, this will dramatically affect the average voltage level in the ESP and thereby the potential cleaning efficiency.

Since the SMPS operates on high frequencies there is a low requirement for energy storage internally in the transformer. Consequently, the size of the high frequency high voltage transformer may be dramatically reduced compared to the traditional T/R. Hence, the total size and weight of the SMPS will be relatively small, and accordingly also with a relatively small dielectric volume.

An SMPS is mainly an electronic product, with power electronics like IGBT's or similar as core components. This offers a wide and flexible range of control possibilities. Electronically based power systems have traditionally been regarded as more fragile and vulnerable than traditional T/R solutions. This is not entirely true anymore as electronics becomes more and more reliable.

Development of a high voltage and high power SMPS is expensive and time consuming due to the complex mixture of high frequency and high voltage demands. So far, a limited number of companies have the competence and experience required to be successful in this field. Hence, very few SMPS's suited for ESP applications have been introduced to the market and thereby a limited variety of voltage levels and power ratings are made available. This has, in many cases, made the utilization of SMPS technology difficult in practical applications.

Based on the above, we may summarize the main disadvantages with the SMPS technology as follows:

- Limitations in available ratings (both voltage and power) will complicate efficient use of SMPS's in many ESP configurations
- Technology has yet a limited track record (and historically also some early reliability issues) and is still regarded with some skepticism by the industry
- Maintaining high-tech electronic components require a re-training of maintenance personnel
- In some cases the SMPS technology seems to struggle in competing with traditional T/R technology when it comes to cost

On the other hand, there are several apparent advantages with the SMPS technology as well:

- + Very low ripple in DC output resulting in potentially better efficiency in the ESP
- + High $\cos \phi$ factor (>0,98)
- + High power efficiency factor (>0,9)

- + Small in size and weight – allows for installation directly at the ESP and thereby potentially reduces construction cost.
- + Contains relatively small dielectric volumes, eliminating special precautions for oil spills
- + Fully electronic control results in high flexibility in applying advanced control strategies

SEARCHING THE “ULTIMATE SOLUTION”

Knowing the potential benefits of the SMPS technology, one can clearly see a promising future for it. However, the disadvantages with the technology and, not to forget, the advantages of the T/R technology, have yet prevented the long announced paradigm shift to happen.

APP has been working with SMPS technology since 1997 and has accumulated an installed volume of more than 150 SMPS's in operation. By this, APP has gained a considerable competence within high voltage electronics and SMPS technology as well as in energizing ESP's. Capitalizing on this competence, APP set forth to develop a new SMPS concept combining the positive attributes from both the SMPS and the T/R world. More specifically, the aim was to develop a concept with the following properties:

- Low ripple DC output signal
- Small in weight and size
- High $\cos \phi$ and power efficiency factors
- High flexibility in re-sizing (in terms of output voltage and power)
- Low cost
- High reliability
- High flexibility in control and operation

The result is a fully modular SMPS concept – the ModuPower™. The modular approach is chosen for several reasons, of which the most important are:

- By decomposing a large problem into smaller entities, the solution becomes simpler
- A modular concept allows for maximum re-use of modules/building blocks, reduces development time/cost and increases quality and reliability of the end product

Obviously, development of a high voltage high power modular SMPS concept is not straight forward and do indeed put a lot of special, and to some extent new requirements to the design. Through new innovations in high voltage transformer design, APP has however been able to make this ambiguous development task come true.

THE MODULAR SMPS CONCEPT – THE ModuPower™

The ModuPower™ concept is a true modular concept, in that the desired output voltage is achieved by cascading high voltage transformers, and the desired output power is achieved by connecting the required number of modules in parallel.

The basic building block

The first step in the implementation is to design a suitable basic building block as shown in fig. 3 below.

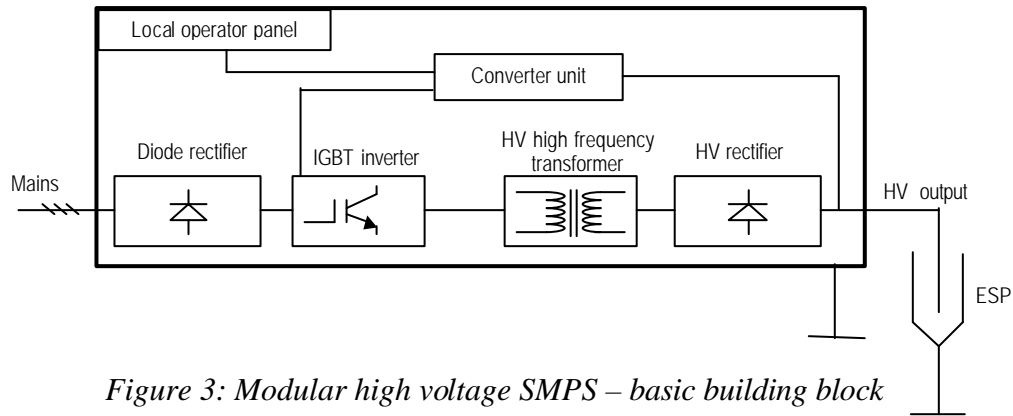

Figure 3: Modular high voltage SMPS – basic building block

This basic building block is basically a conventional high frequency SMPS design. However, some specialties are introduced to make it well suited for the modular concept.

- The high voltage transformer is given a design well suited for cascading.
- The high voltage transformer design follows completely new conventions resulting in extremely low losses and very high bandwidth. These are properties essential to allow for advanced transformer control and also to further reduce weight and size.
- A traditional high voltage SMPS is based on a resonant design, meaning that the properties of the load (mainly the capacitance of the ESP) is an important part of the SMPS inherent protection system. Consequently, uncontrolled changes in the load properties (e.g. open circuit or short circuit between ESP fields) may damage the SMPS. The ModuPower™ is based on a hard-switching control strategy as described in [4]. This makes control of the unit independent of the connected load, which again makes it possible to connect two (or more) units in parallel to the same load. Furthermore, the resulting system is very robust in handling uncontrolled changes in the load (ESP) properties.

APP has chosen to design this basic building block with an output voltage of 50 kV and a power rating of 30-50 kW to suit our own compact ESP applications.

Boosting output voltage

The next step in the process is to increase the output voltage to the desired level by connecting high voltage transformers in a cascade configuration. Fig. 4 illustrates how this.

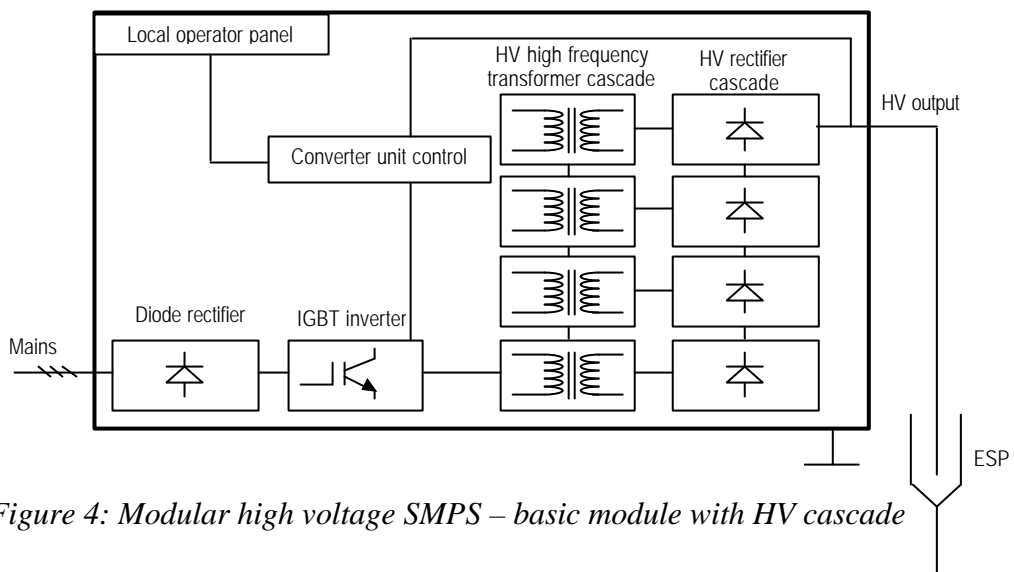

Figure 4: Modular high voltage SMPS – basic module with HV cascade

The high voltage cascade chain is made true modular, in that each element only sees a max differential voltage equal to the voltage raise in the same element. The implication is that if the voltage is raised by 25 kV in each of the elements in the cascade, each element will only experience a differential voltage of 25 kV. In this way we have decomposed the challenge of handling large differential voltages to manageable entities internally in the construction, and only have to deal with the full output voltage when bringing it out to the load. In principle, it is possible to achieve a very high output voltage with this design approach. APP has however decided to stop (at this stage at least) at 120 kV, adequate to supply a 400 mm spacing ESP.

Due to the modular concept of the high voltage cascade, also the output rectifier is made modular. This actually opens an interesting additional possibility. In some applications, like when energizing corona shower reactors, one wishes to superimpose an AC signal on top of a DC signal. Dimensioning the last element of the cascade chain according to the desired amplitude of the AC component, and omitting the rectifier for this element, achieves this property in the ModuPower™ concept. The AC frequency will, in that case, be identical to the switching frequency of the SMPS. In the ModuPower™, the switching frequency is set to 35 kHz.

Completing the modular concept by connecting units in parallel

Once we have established the desired output voltage by adding elements to the high voltage cascade chain, we may introduce the final dimension in the modular concept, deciding the output power rating. This is simply achieved by connecting the required number of basic modules in parallel feeding the same load (ESP). This is illustrated in fig. 5 below.

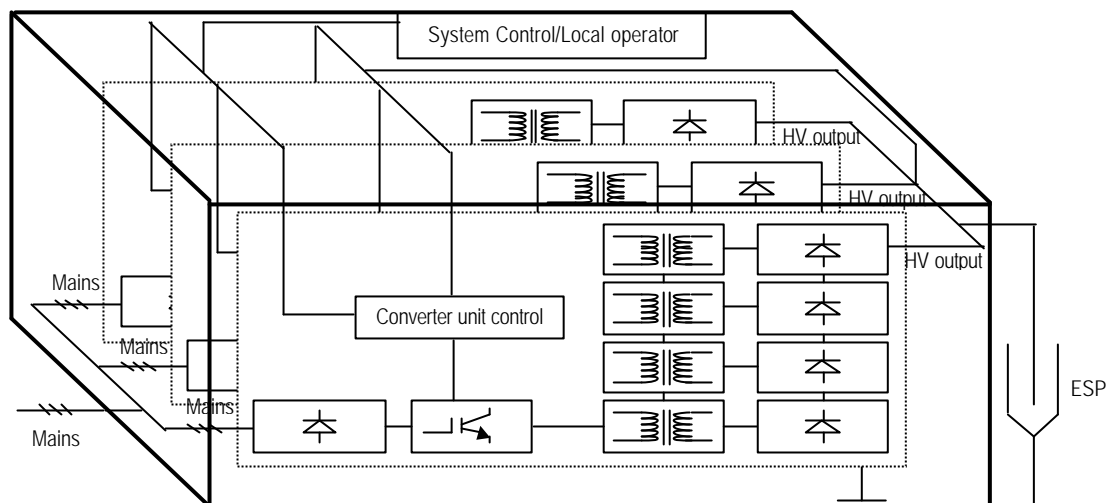

Figure 5: The full modular high voltage SMPS concept with multiple modules in parallel

A traditional high voltage SMPS will have a resonant design and thereby forbid connecting units in parallel. With the ModuPower™ SMPS, being a hard switching design, connecting in parallel is a possibility, even without any synchronization between the parallel units. For practical purposes, the ModuPower™ concept does however include a system control, handling inter-module communication as well as external communication (to operator and/or supervisory system).

By adding the horizontal dimension to the ModuPower™ concept, the output power rating may be tailored to the specific needs. There is in principle no limit as to how many units you may connect in parallel. It will however be limited by the actual practical need in the market. APP would expect ratings up to 300 kW will cover most needs, but cannot see any real obstacles to move beyond this limit if required.

Control considerations for the ModuPower™ concept

From an ESP end-user point of view, it is vital that the power source is easy to use and intuitively easy to understand. Even if the ModuPower™ concept is built out of simple and logical building blocks, operating them independently will obviously be complicated. Hence an advanced control system is an integral part of the system enabling the ModuPower™ unit to be experienced and operated as one unit even though may consist of several units in parallel.

On the basic building block level, a converter unit control handles the local control of the building block and communication with a supervisory system control. In the system control, coordination of parallel basic building blocks is handled as well as all communication with the outside world.

Each ModuPower™ unit is equipped with a local operator panel, allowing the operator to configure and operate as well as monitor vital parameters in the ModuPower™ unit. The unit also offers a standard Ethernet TCP/IP interface for network connection. A browser interface integrated in the system control unit, will allow an easy access to the ModuPower™ unit with standard browser software (i.e. Microsoft explorer etc.). Alternatively, purpose built PC-based operator interface software may be implemented to connect to and operate several ModuPower™ units in one system (useful when several ModuPower™ units serves different fields of an ESP). A supervisory control system may interface the ModuPower™ units via the TCP/IP network connection or via standard hardwired signals.

PRACTICAL IMPLICATIONS OF THE ModuPower™ CONCEPT

As mentioned in the introduction to this paper, there are some main limitations and concerns related to the SMPS technology, preventing it from being as wide spread as predicted some years ago. Having the ModuPower™ concept in the toolbox, we envisage the possibility to remove the limitations and minimize the industry concerns to an acceptable minimum.

- Lack of flexibility in output voltage and power rating: By introducing the ModuPower™ concept nearly all possible ESP configurations may be energized. Fig. 6 illustrate the flexible output properties of the ModuPower™ concept.

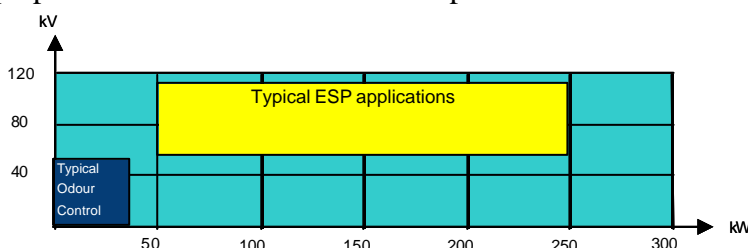

Figure 6: ModuPower™ – available output voltage and power ratings

- Lack of reliability: With a proper design, there are few (if any) sides of the SMPS technology that should make it less reliable than a modern T/R set. Practical experience with both earlier APP SMPS's as well as products from other SMPS vendors, have shown

that high reliability products indeed are available. Even with a high reliability SMPS design as basis, the ModuPower™ concept offers some additional features making it potentially even more reliable.

- The modular concept opens for installing redundancy in the system, making it fault tolerant. Typically, if you need 150 kW output, you may install a ModuPower™ unit with 200 kW output and accept a fatal fault in one of the basic modules without affecting the performance of the system as such.
- The hardswitching design in the ModuPower™ makes the output control independent of the load, and thereby robust against uncontrolled changes in the ESP.
- Lack of cost competitiveness: The modularity of the ModuPower™ concept makes it more scalable than traditional SMPS's and may thereby be cost competitive in a wider range of applications. It is also inherent in the modular approach, the re-use of module-design in series and parallel, potentially reduces unit cost. Size and weight of ModuPower™ is further reduced compared to traditional SMPS designs (<50%), which opens for an even more optimized and cost efficient installation. All these elements put together makes the ModuPower™ concept potentially competitive compared with T/R's on a wide variety of applications.

In addition to these benefits, the ModuPower™ concept does offer the general advantages of the SMPS technology in ESP applications as described earlier in this paper.

CONCLUSIONS

With gradually more stringent legislative requirements to filter output, both in terms of particle content and particle size distribution, ESP optimization is unavoidable. We believe the SMPS technology makes this optimization possible and will in future be a necessity for the ESP technology to maintain its dominant position in the market.

Through the introduction of the modular high voltage SMPS concept, the ModuPower™, the main arguments against utilizing SMPS in ESP applications have been addressed and removed. This opens for the long announced paradigm shift in ESP energization to happen.

APP have already taken its modular power concept, the ModuPower™, into use in own ESP applications, and are now ready to move to the next step by providing solutions to the general ESP industry.

REFERENCES:

1. "On experiences of the application of high-frequency power converters for ESP energisation", Ranstad, Mauritzon, Kirsten, Ridgeway, ICESP IX, 2004.
2. "Full scale test with Switched Mode Power Supplies on an ESP at high resistivity operating conditions", Reyes, Lund, ICESP VIII, 2001
3. "Applied electrostatic precipitation", Parker, ISBN 0-7514-0266-4
4. "Hard switching – a superior switched mode power supply for ESP's", Wetteland, ICESP VIII, 2001