

EFFICIENCY IMPROVEMENTS ON LARGE INDUSTRIAL ELECTROSTATIC PRECIPITATORS WITH IGBT INVERTER TECHNOLOGY

NORBERT GRASS
University Of Applied Science
Dep. Power Electronics
Nuernberg, Germany
Norbert.Grass@fh-nuernberg.de
in cooperation with Siemens AG

ABSTRACT

By increasing the precipitator efficiency the stack emissions and operating costs can be reduced. During the operation of a precipitator different load and dust conditions need to be handled. In many applications fuel needs to be switched to lower sulfur contents leading to lower electrical conductivity of the dust. Often, precipitators are to be operated outside their design data. Due to the high cost of a mechanical precipitator extension, the preferred solution is upgrading the high voltage power supply to achieve the regulating authority's required stack emission limit. Large industrial precipitators with multiple fields can be operated with different types of high voltage supplies for optimum precipitator performance and operation. IGBT inverter based high voltage supplies used in the inlet fields can increase the average corona power significantly. Additionally, the fast flashover reaction helps to increase the average voltage even with high flashover rates. Thus the particle charging and the flashover frequency can be optimized, and particle collecting will be improved even in the following fields. Fine particles can be treated by short pulses generated by IGBT based technology in the outlet fields. Due to the networking features of the different types of high voltage power supplies the total performance and power consumption of a precipitator can be continuously optimized depending on the operation conditions.

IGBT inverters can be designed in resonant and hard-switching modes. The details of both types will be discussed and the higher flexibility of the hard-switching will be shown.

Furthermore, the power consumption of large precipitator needs to be considered, particularly, in large IGBT inverter installations. With power management huge power savings are possible while the stack emissions are kept low. Therefore, the precipitator efficiency could be significantly improved by achieving both, lower emissions and lower power consumption.

IGBT INVERTER TOPOLOGIES

There are different concepts and topologies for low voltage side IGBT inverter based power supplies. The basic circuit is shown in Fig. 1. There are resonant switching and hard switching topologies. To achieve resonant switching, a capacitor needs to be added to the circuit shown in fig. 1.

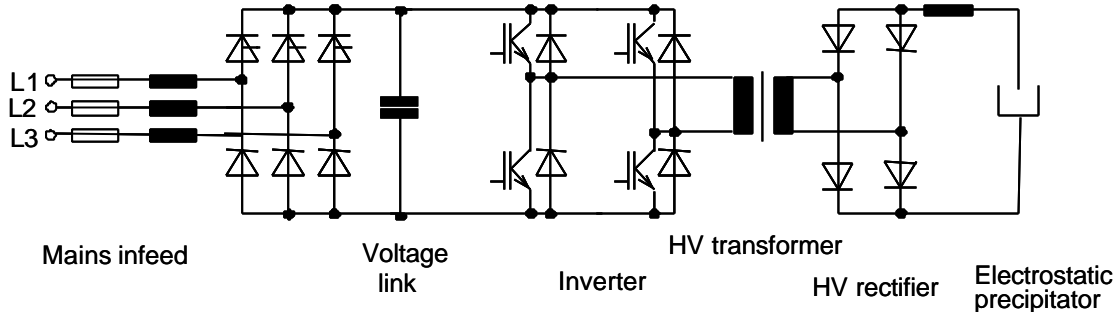

Figure 1: Basic IGBT inverter circuit

The most common topologies will be compared in the following table 1:

Table 1: properties of common IGBT inverter topologies

| | resonant | hard switching |
|----------------------------|--|---|
| Current waveform | | |
| Phases | 3 | 3 |
| cos φ | ~ 1 | ~ 1 |
| Operating frequency | high (e.g. 50kHz-80kHz) | moderate (500 Hz / 10 kHz) |
| power losses (cond.) | high (fast IGBT needed, higher V _{CE0}) | low (high current type IGBT, lower V _{CE0}) |
| switching losses | low energy losses per switching event, but higher frequency | higher energy losses per switching event, but lower frequency |
| TR set operating frequency | 50 kHz – 80 kHz | - 500 Hz (optimum) - 50 Hz / 60Hz using standard TR set |
| Power supply upgrade | Always inverter and TR set | Reuse of existing TR sets possible |
| TR set type | low losses (ferrite) | 500 Hz or standard 50 Hz/60Hz |
| TR size | Similar for the same voltage rating. High voltage requires insulation distance | |
| Distance inverter – TR | not possible due to high frequency | - 500 Hz TR: 120m - 50/60Hz TR: any |
| maximum power | 100 kW | 300 kW |
| maximum voltage: | 70 KV (DC) | 110kV (DC) |
| maximum current: | 1,4 A | 3,3 A |
| Flashover reaction | 40 μs | 50 μs |
| Flashover current increase | small | no |

The most significant difference between the two concepts is the type of magnetic core used in the transformer design. The resonant circuit has an inherent high current ripple, therefore a high frequency is required to achieve a constant DC voltage, regarding the electrical capacity of the precipitator to flatten the voltage. For those high frequencies it is very difficult to build

a magnetic core with low stray inductance and losses but with a large size in order to hold high voltage insulation.

Therefore, Siemens decided to use the hard switched concept, being able to build TR sets for up to 110 kV and power up to 300 kVA. The advantages in the precipitator control can be realized with both concepts. A further important advantage of the hard switched concept is the much higher flexibility in upgrading existing precipitator plants. The IGBT inverter and the TR set can be separated as used in the previous installations. If the existing TR set is in sufficient state and rating it can be reused and operated from the IGBT inverter. There is of course a small disadvantage resulting from the higher stray inductance of the standard (i.e. 50Hz / 60 Hz) TR compared to the 500 Hz type, which results in a higher current turn off time after a flashover has been detected. But the flat DC voltage can be applied even with the standard TR set to gain a significant performance improvement in many installations. Additionally, a trial installation becomes very simple, because the inverter only has to be connected to the existing TR set. Of course, the IGBT inverter control is able to interface all standard control signals easily.

LINE COMMUTATED THYRISTOR BASED HIGH VOLTAGE POWER SUPPLY

The silicon controlled rectifiers type (SCR) high voltage supplies are still available on the market and they can be equipped with new, powerful control to be linked in to the total precipitator optimization. There is just one but significant advantage of this technology: The cost of the power electronics components is very low compared to the IGBT inverters. Therefore, if the bad power factor is not a problem, it is usable for Electrostatic precipitator fields with lower requirements regarding the voltage quality and flashover reaction. In large installations this commonly is the case in the middle fields of the precipitator. Large precipitators can benefit from the combination of IGBT inverters and SCRs, as IGBT inverters can be used to stabilize the operation of the consecutive fields. With high current in the first fields the flashover rate in the following fields significantly decreases while the voltage can be increased.

IGBT INVERTER FUNCTIONAL DESCRIPTION

The application of modern power electronics with IGBT-switching devices (Insulated Gate Bipolar Transistors) and fully digital micro controller units with high speed parallel processing and multitasking properties significantly increase the efficiency of an electrostatic

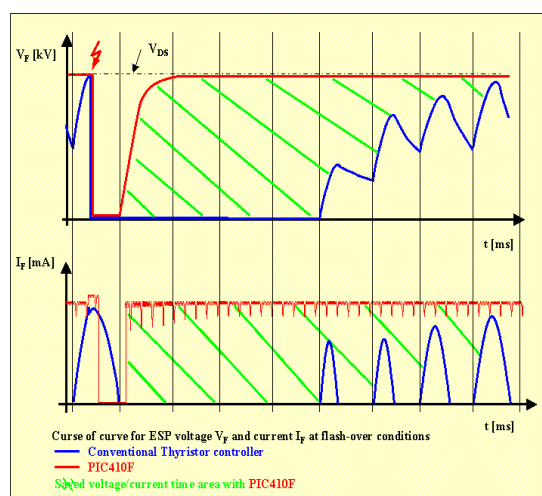

Figure 2: precipitator voltage and current

precipitator. Cost savings for new projects can be achieved due to smaller dimensional requirements of the precipitator plates. In the cases with back corona, advantages can be attained with pulsed operation because of shorter intervals in comparison with Thyristor power supplies.

Short switching times for the power semiconductors (IGBTs) of around 200ns in contrast to the 10ms of conventional equipment prevents the precipitator from high local ionization at flashovers. Therefore the mean field strength increases thanks to short de-ionisation times and fast recovery to target voltage levels.

The IGBT inverter has a 3-phase mains input rectifier with a power factor ($\cos \phi$) near unity and no compensation is required. A voltage link capacitor is used as a low inductance current buffer for the H-bridge IGBT-inverter. The low inductance between capacitors and IGBTs is achieved by a planar busbar design considering the current paths during operation of the inverter. The switching frequency is typically 10kHz. The current inversion frequency has been selected at 500Hz, therefore standard materials for the high voltage transformer can be used. Technically it is possible to operate on higher frequencies, but the cost saving on the transformer would be marginal. Further size reduction can't be achieved because of the mandatory distances according the high voltage inside the oil filled tank.

The electrical power of a typical unit is up to 300kVA, which is easily extended by using larger IGBT-devices. The output voltage is very constant with a negligible voltage ripple. Therefore the average voltage of the precipitator can be increased up to a level close to the flashover limit of the entire precipitator. During operation the flashover limit can vary widely, therefore flashovers can't be avoided. It is a stochastic process, therefore flashovers can't be detected prior happening. The flashover reaction of the IGBT inverter is much faster compared to a line commutated thyristor switch. Due to the shorter arc duration less space charge is generated and the requested de-ionization time can be selected shorter. After de-ionization time, the current rises within 100 μ s up to the calculated value, much faster than a line commutated thyristor power supply can be operated. Resulting from the above mentioned effects, processing of a flashover needs an interruption of the power supply of about 2ms...10ms, comparing to 20ms to 100ms with a line commutated thyristor power supply. Therefore, a higher flashover repetition rate can be allowed with the IGBT inverter resulting in higher average electrical power and lower dust emissions. Fig. 2. shows the voltage and current signals of an IGBT inverter power supply compared with the conventional line commutated thyristor supply, including flashover processing.

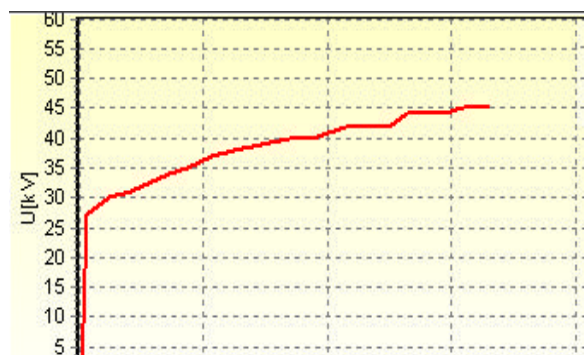

Figure 3. V/I characteristic example.

The average precipitator current can be increased significantly due to the flat V/I (Fig. 3) characteristics of a precipitator. A small voltage increase results in a greater current increase. In practice it was possible to increase the electrical power by up to a factor 3 times in many cases.

The low amount of energy consumed in a single flashover lowers the stress of the electrodes in the precipitator. Thereby life time of the material can be increased. This effect is very important if plastic collecting electrodes are used. The energy of a flashover W_{FO} consists of two parts. The energy stored in the capacity W_{CAP} of the precipitator is a fix amount, depending on the applied voltage and it can't be influenced from the power supply. The energy delivered by the power supply from the flashover detection until the current is switched off W_{PS} is significantly lower with the IGBT inverter because there is no over-current and switch off can be completed within 100 μ s.

The IGBT inverter and the high voltage transformer / rectifier unit are shown in Fig. 4.



Figure 4: IGBT HV power supply 200 kVA

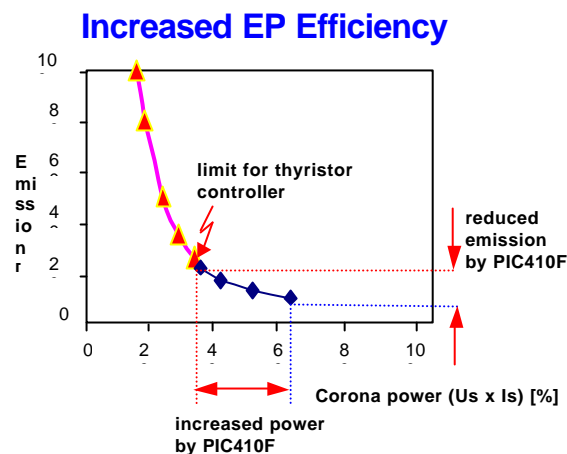

Figure 5: Emission over power

Fig. 5 shows the dependency of the Emission on the corona power. In respect to Fig 2 the higher corona power due to the constant DC voltage leads to a significant reduction of the emissions.

EXAMPLE: FOSSIL POWER PLANT

Measurements of the precipitator efficiency were taken on one precipitator duct, which consists of 5 fields, whereby fields 1, 2 and 5 are equipped with IGBT inverter power supplies and fields 3 and 4 are equipped with new controllers and thyristor power supplies. The efficiency was measured by an opacity meter for the duct separately, therefore changes in opacity responding to changes of electrical values could be observed reliable on the opacity signal.

Starting conditions of the test were as low electrical power as possible in all fields with the opacity signal not exceeding the limit. Then the opacity measurement responded very reliable to the electrical changes. The goal was to determine the efficiency (i.e. opacity / el. Power) of each field in the duct. To run the entire field in realistic conditions, the electrical currents had to be increased separately for all fields, starting with the first field and then in the following fields in the gasflow.

Fig. 6 shows the current of field1 and the opacity signal during the experiment. The scale of the opacity signal is not shown in Fig. 5. On field 1 it can be seen that with a standard SCR

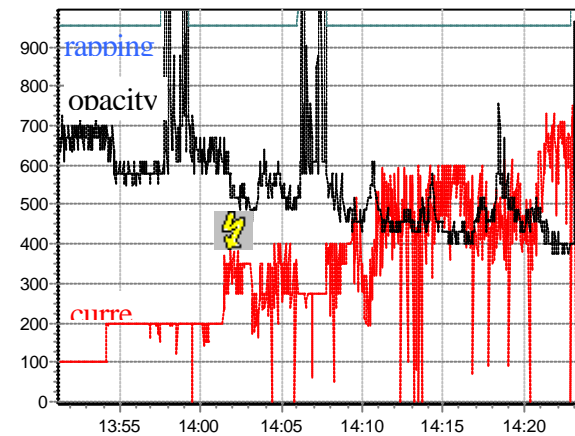

Figure 6. opacity and current – inlet field

power supply about 350mA could be reached due to the flashover limit of the precipitator (see Fig. 5). With the fast switching IGBT inverter power supply the current could be increased to values about 700mA. The following table shows the relating opacity values.

During the cleaning of the dust collecting electrodes (rapping) the opacity increases significantly if the current is low. During rapping a vibration of the plates causes the dust layer to slide down the plates. The gas flow, due to the soft packing of the dust layer causes some particles to be released into the gasflow. In case of high electrical current the dust layer becomes more firm because of the higher migration velocity and dust re-entrainment during rapping is reduced

Table 2

| | Thyristor | IGBT | Improvement |
|------------|-----------|------|-------------|
| Iprim[mA] | 350 | 700 | 100% |
| Opacity[%] | 10-12 | 8 | 20-30% |

Similarly effects could be obtained when the current in field 2 was increased. The values are:

Table 3

| | Thyristor | IGBT inverter | Improvement |
|----------------|-----------|---------------|-------------|
| $I_{prim}[mA]$ | 500 | 650 | 30% |
| Opacity[%] | 7 | 5.6 | 25% |

The effect of the currents of fields 3 and 4 is much smaller. That was already expected because of the high efficiency of fields 1 and 2 the role of fields 3 and 4 is to collect the already charged particles. Therefore the flashover rate is much lower there and due to the smaller quantity of particles reaching fields 3 and back corona effect is also low.

On field 5 the increase of current did not result in a big change in the average value of the opacity but the opacity peaks during rapping are mainly disappearing and therefore the

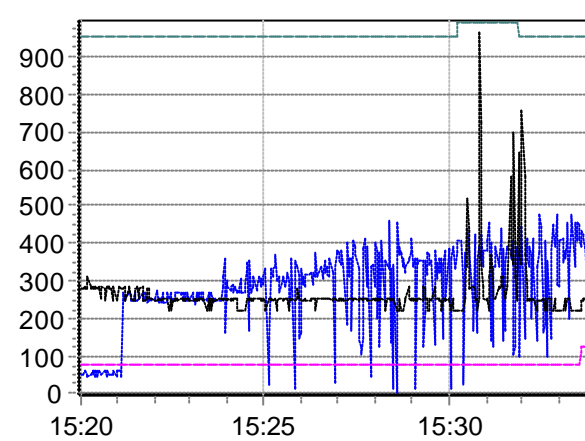

Figure 7. opacity and current –

average opacity is decreased. It was found that the high electrical power in the outlet field is required during rapping of the outlet fields. Between the rapping events energy can be saved by dropping down the electrical power. The IGBT inverter is able to increase the current very fast in comparison with the SCR, improving process efficiency.

FIELDS OF IGBT INVERTER APPLICATIONS

IGBT inverters have been successfully installed in large electrostatic precipitators in power plants as shown above. One of the first applications was in a steelworks on a precipitator with 3 fields. Stack emissions were reduced by about 50%. Other metallic plants also showed similar results. There are installations in cement plants as well and efficiency improvement was achieved there, too.

POWER CONSUMPTION

Some development has been done in the field of lowering the average power consumption of precipitators with IGBT inverters in operation. Fuzzy Logic adapts the electrical behavior continuously according to the process conditions.

Additionally, new control and communication features have been implemented. After networking the entire high voltage power supplies with a WINPIC optimizing and diagnostics computer additional features like energy management for huge precipitators are available. The emission monitoring signal from the stack is used as control signal. According to a three

field precipitator model the corona power of each electrical field is individually regulated. Typically, savings are up to 1MW on large precipitators.

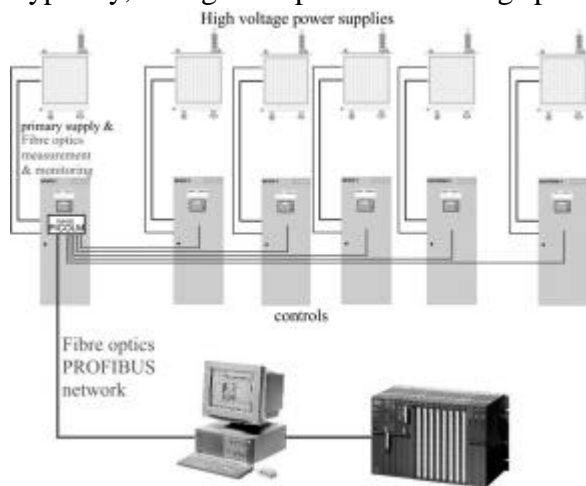

Fig. 8: Power control system "WINPIC"

REFERENCES

- 1 E. Kuffel, W.S. Zaengl: "High-Voltage-Engineering" Pergamon Press Oxford, New York, Beijing, Frankfurt, Sao Paulo, Sydney, Tokyo, Toronto 1986
- 2 D.A. Lloyd: Electrostatic Precipitator Handbook Bristol, 1988
- 3 Harry J. White: Entstaubung industrieller Gase mit Elektrofiltern VEB Deutscher Verlag für Grundstoffindustrie Leipzig, 1969
- 4 Norbert Grass: Fuzzy Logic-Optimising IGBT Inverter for Electrostatic Precipitators, Conference Proceedings IEEE IAS 1999 annual meeting, Phoenix, 4-7. Oct. 1999
- 5 Norbert Grass: Fuzzy-Logik-gesteuerter Spannungs-Zwischenkreis-Umrichter für Elektrofilter, Dissertation 1997, University of Erlangen, Germany
- 6 Norbert Grass: Application of different types of high voltage supplies on industrial electrostatics precipitators, IEEE Trans. Plasma Sci. Vol. 28, no. 5, 2000, pp. 1481-1485
- 7 Norbert Grass: "Fuzzy-Logic-Based Power Control System for Multifield Electrostatic Precipitators" IEEE Transactions on Industry Applications, Vol. 38, No 5, 2002
- 8 Norbert Grass, Werner Hartmann, Michael Klöckner: "Application of different types of high-voltage supplies for electrostatic precipitators" IEEE Transactions on Industry Applications, Vol. 40, No 6, 2004
- 9 Lucian Dascalescu, Michaela Mihailescu, Akira Mizuno, "The behaviour of conductive particles in pulsed corona fields", Journal of Physics, D:Applied Physics. 29 (1996), pp. 522-528