

Study on Spraying Corona Discharge Technology with Grounding¹ Discharge Electrodes for Purifying Flue-gas

Dexuan Xu, Shanshan Lin, Yujia Wang, Zhiming Guo, Weili Ge
Department of Environmental Science and Engineering, Northeast Normal
University, Changchun 130024, China (E-MAIL: xudx245@nenu.edu.cn)

Abstract: This study focused on a new electrostatic precipitation technology of spraying corona discharges with grounding discharge electrodes for purifying flue-gas. DC positive high-voltage was connected to collecting electrodes and water discharge electrodes were grounded. A lasting and effective electrostatic removal of dust with minimized drain water would be achieved by wet or semi-wet spraying corona discharges. The experimental researches on discharge characteristics and cleaning effects of both collecting and discharge electrodes by wet spraying corona discharges were carried out. The treating circulating water and the removing gas contaminant by corona plasma were analyzed. The discharge characteristics of semi-wet corona discharges also were researched. The advantages of spraying corona discharges with grounding discharge electrodes for purifying flue-gas were discussed. The researches have supplied the foundations of theory and design for purifying the flue gases with fine and adhesive dusts using spraying corona discharges.

Keywords: Spraying corona discharges, Grounding discharge electrodes, Purifying flue gas, adhesive dusts

1. Introduction

In varied sources of atmosphere pollution, there is a kind of pollution sources containing a large number of adhesive and fine suspending particles, whose diameters range from sub-microns to few microns, for example, the cooking fume of restaurants and the soot of asphalt or diesel oil exhaust. It is difficult to remove the adhesive dusts or droplets from flue-gas using the traditional methods. The discharge electrodes in electrostatic precipitation could be wrapped by the adhesive particles and the corona discharges stopped. The filter holes could be blocked in the filtration precipitation. All the two efficient precipitation could not run for a long time because of the adhesive particles. Therefore, the new mechanism and technique for precipitation and gas purifying are being researched, in order to resolve the difficult problems.

A kind of charged droplet scrubber was manufactured to form the spraying of high voltage jets using the mechanism of electro-hydrodynamic (EHD) spraying^[1]. But the high voltage insulation of the supplying water system had to employ an extraordinary long insulation water pipe. We researched the electrostatic precipitation technology with discharge electrodes ejecting saturation steam, which is difficult to be applied without available steam source^[2]. In recent years, many experiments and researches have demonstrated that the technology of spraying corona discharges with grounding discharge electrodes for purifying flue-gas is promising in the applications^[3]. Now two sample machines have been designed, one is wet type and another is semi-wet type, in order to research the operation characteristics of the precipitation with grounding and spraying discharge electrodes.

2. Experimental researches on wet spraying corona discharges with grounding discharge electrodes

The wet spraying corona discharges are an electrostatic spraying state with some sprays ejected

¹ "Project 50277004 supported by National Natural Science Foundation of China"

from the discharge electrodes. The spraying water droplets impact the collecting electrodes and form a thin water layer on the collecting electrodes. After the solid contaminants were separated, the dripped down water from the collecting electrodes is pumped to discharge electrode as the circulating water.

The experimental apparatus for the wet spraying corona discharges with grounding discharge electrodes is shown in Fig.1.

A pair of plate electrodes 2 was connected to a HV power supply 8 through the HV cable 7. A discharge electrode 1 was grounded through tube dividing water 12, soft tube 3, valve 4 and water container 5. All the processes of precipitation, the electrode clean and the plasma treatment for circulating water were operated between the discharge electrodes 1 and the HV plate electrodes 2. The water between the electrodes 1 and 2 dropped into a water basin 9, and was pumped into a water container 5 by the pump 10. Then the water flowed down into the discharge electrodes through a valve 4, which was regulating the flow rate. All the supplying water system and the discharge electrodes were grounded. A discharge electrode with small curvature could form uneven electric field and produce stable corona discharges under the induction of HV plate electrodes. The discharge electrode was made of the stainless steel wire with 1mm diameter and 700 mm length. The water on the discharge electrode flowed down from a hole of the tube dividing water and some approaches of avoiding block were installed in the hole. The HV plate electrodes were made of stainless steel with 900mm in height and 500mm in width. The HV electrodes were suspended and fixed on an insulating bracket. The spacing D between plate electrodes was 300mm. Because negative HV DC discharges have stable Thichel discharge model^[4], the positive HV DC power supply was connected to the plate electrodes. We could read the HV value of the plate electrodes using a HV divider. Between the low terminal of power supply and the ground wire an ampere meter was inserted, in order to measure the discharge current.

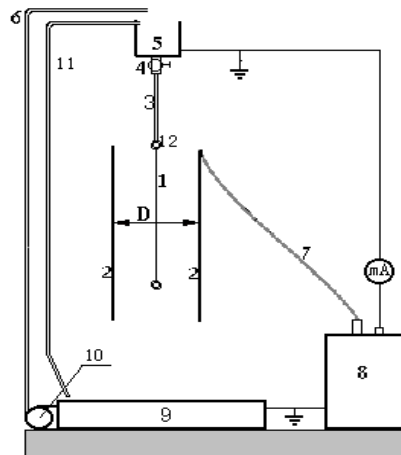

Fig.1 Schematic of experimental apparatus with wet spraying corona discharges of grounding discharge electrodes

- 1.Discharge electrode 2. HV plate electrode 3. Soft tube 4. Valve 5.Water container 6. Water tube
7. HV cable 8. HV power supply 9. Water basin 10. Pump 11. Overflow tube 12. Tube dividing water

When positive HV is applied on the plate electrodes opposite to the water-wire electrode, the non-uniform electric field is formed between wire and plate electrodes. The very strong electric field occurs near the surface of the water-wire electrode, because the curvature radius of the electrode is much smaller than that of plate electrodes. The electric field produces an electrostatic force, which is outward and perpendicular to the water surface. The electrostatic force is proportional to the electric field strength. Therefore the instability of water surface increases and the Taylor Cones are formed. The Taylor Cones are forced by both the electrostatic force and the gravity, extending outward to form filament flows. When electric field is strong enough, the numbers of filament flows increase and at their ends EHD spray phenomena are produced. The spraying droplets with diameters bigger than $20 \mu\text{m}$ were observed in the similar condition. When voltage is higher than the onset voltage of corona

discharges, besides the mechanism of EHD spray, the water sputtering is produced too. At this time, the positive ions were produced by corona discharges and bombard the water surface of water-wire electrode.

The spraying droplets of spraying corona discharges were analyzed by microscope, when the discharge electrode was grounded. The spacing between discharge electrode and plate electrodes was 50 mm. When HV was 12.7 kV, the stable corona discharges occurred and perfect multi-dispersion spray was formed. A lot of droplets with a diameter about 100 μm existed in the aerosol. But there are only a few droplets with a diameter above 1 mm in it. The mass of the droplets with a diameter above 80 μm was above 99.6% of total droplet mass. Therefore the droplets above 80 μm produced by EHD spraying play a very important role in the electrostatic precipitation of spraying corona discharges.

When the spacing D between two HV positive plate electrodes was 300mm and water flow rate on the discharge wire was 464 ml/min for each meter of discharge electrode, discharge characteristics of the corona discharges with dry discharge electrode or wet spraying one were respectively measured. Their V-I characteristic curves were shown in Figure 2.

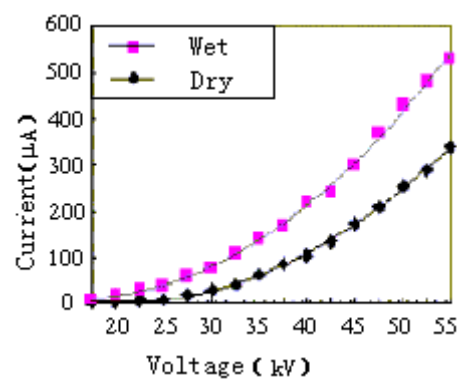

Fig.2 I-V characteristic curves of wet spraying corona discharge

The figures shown that the onset voltages of negative corona with spraying water were obviously lower than that of dry corona discharges. This phenomenon is attributed to the different diameter of discharge electrode. The diameter of dry corona discharge electrode was 1 mm. in dry negative corona discharges. In wet spraying corona discharges, the onset voltages were determined by the diameter of filament flows, which were produced by EHD instability of water surface. The filament flows extended from discharge electrode downwards and outwards. Their diameters can get smaller than 0.2 mm, which were much thinner than that of dry corona discharges. Therefore the onset voltage of negative corona with spraying water was lowered.

In dry negative corona discharges, discharge current consisted of free electrons and negative ions existing between two electrodes. There were a lot of free electrons and the negative ions produced by electron attachment on molecular of negative electric gases in the ionized region near the discharge electrode. Both electrons and negative ions moved to positive plate electrodes under the electric field. Because the electric field strength decreases steeply with the increase of distance from discharge electrode, the free electrons out of ionized region had no enough energy to ionize gas molecular. Therefore more and more electrons attached on the gas molecules and formed negative ions. At last, almost all of the charge carriers collected on the plate electrodes were negative ions.

In wet negative spraying corona discharges, besides above process lots of highly charged droplets were produced. Because the water surface on discharge electrode accumulated lots of negative charges under electric field, the water droplets had to carry the charges and formed charged droplets when they left the water surface. The droplets can be charged further in the near-ionized region of corona discharges. In this region not only the strength of electric field was very strong, but also the concentration of both free electrons and negative ions were much higher. The droplets were further charged by ions according to mechanism of electric field charging and diffusion charging. Especially a large number of free electrons existed in the near-ionized region [5]. The free electrons

have higher energy than gas molecule ions. Therefore they not only charged bigger droplets effectively, but also charged smaller droplets continually, which could easily achieve their saturation charges in the process of ion electric field charging.

Under the same voltages, the current of wet spraying corona discharges was higher than that of dry corona discharges. In dry corona discharges, the measured current included only interelectrode ion and electron currents. In wet spraying corona discharges, addition to the above-mentioned currents the measured current also included the current of spraying droplets and the dump current from dropping water of plate electrodes. When supplying water was minimized, the measured currents were almost same in dry and wet conditions.

The highly charged droplets had bigger charge-mass ratio and higher migration velocity. The efficient electrostatic and dynamic agglomeration between the droplets and dusts occurred in the flue gas^[6], which never produced in the traditional electrostatic precipitators. Therefore the precipitation of spraying corona discharges had higher precipitation efficiency.

In spraying corona discharges, the spraying of water on the surface of discharge electrode was produced continuously. So discharge electrode can be cleared during the operation period, which could not be realized in the traditional electrostatic precipitation.

In order to demonstrate the cleaning effects of the plate electrodes, a thin layer of adhesive wet fly ash was smeared on the plate electrode before the operation. The spacing between plate electrodes was 300 mm, water flow rate on the discharge wire was 464 ml/min for each meter of discharge electrode, positive high voltage was 55 kV and current was 530 μ A. The results were shown in Figure 3 after 3 minutes discharges. The dark area on plate electrode was thoroughly cleared by water. Therefore, the adhesive liquid or solid particles in flue gas could not adhere to collecting electrodes. They bumped water film of plate electrodes and were brought away by water film immediately. Comparing with traditional wet electrostatic precipitators, the precipitation of the spraying corona discharges not only saves water, but also has higher effects for cleaning plate electrodes.

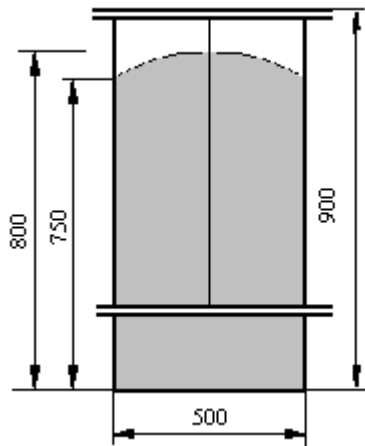

Fig.3 Cleaning effects of HV plate electrode

The corona discharges and EHD spraying have function of decolorization. The experiment on the decolorization of indigo solution was carried out using spraying corona discharges. The initial concentration of aqueous solution of indigo carmine ($C_{16}H_8N_2Na_2O_8S_2$) was 5.0×10^{-5} mol/l. A spectrophotometer (1 cm path length) was used for measuring decolorization rate. When air gap was 30 mm and high voltage was 25 kV, the decolorization rate can get to 80.8% in 30 minutes.

The experiment of killing bacteria in water using EHD spraying was reported^[7]. In the spraying corona discharges, when circulation water system was employed, it was possible to treat the water for a long time. The odor, colors and some harmful organism could be removed. Some microorganisms that conduce corrosion and blockage could be killed. Even though the circulating water includes some soluble organic compound after a long time operation, they are easily removed without polluting atmosphere. It is because most droplets have a diameter above 80 μ m and higher charges.

The spraying corona discharges also have the potential function of removing the harmful gases from flue gas. The experiment of DC corona discharge on water surface indicated that corona discharge provide a good condition for removing NO_x with the water existing^[8].

3. Experimental researches on semi-wet spraying corona discharge with grounding discharge electrodes

The semi-wet spraying corona discharges with grounding discharge electrodes are a kind of electrostatic sprays with a little spray ejected from the discharge electrodes. There are dilute liquid or moist solid contaminants on the collecting plate electrodes. In the precipitation process, the humidity of emitted flue gas is added and polluted water draining does not occur.

The experimental apparatus for the semi-wet spraying corona discharges with grounding discharge electrodes is shown in Fig.4. Needle-plate configuration was employed in the experiment. The needle discharge electrode 1 was made of the stainless steel wire with 0.5mm diameter and 2 mm length. The needle electrode protruded from a glass-reducing pipe 3. The flow rate on needle electrode was supplied by a water container 5 and adjusted by a valve 4. The HV electrodes 2 were made of two stainless steel plates of 200mm×200mm. The spacing between the two plate electrodes can be adjusted. Between the needle electrode and the ground wire an ampere meter was inserted, in order to measure the influence of water flow rate on corona discharges. The water flow rate was measured by the decrease of water surface height during the spraying.

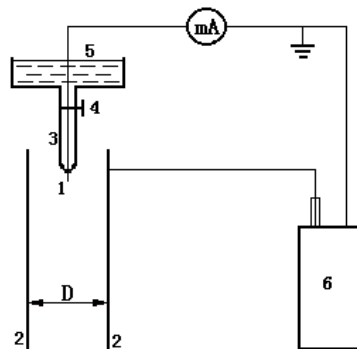

Fig.4 Schematic of experimental apparatus for semi-wet spraying corona discharges with grounding discharge electrodes

1. Needle electrode 2. HV plate electrode 3. Glass pipe 4. Valve 5. Water container 6. HV power supply

When the spacing between plate electrodes was 100mm and positive HV was applied to the plate electrodes, the negative corona currents of semi-wet spraying discharges were compared in different water flow rates. The result was shown in Fig. 5.

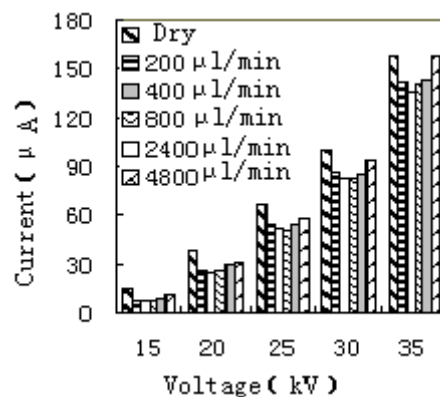

Fig.5 Influence of water flow rate on discharge characteristics in spraying corona discharges with point discharge electrode

The figure indicated that discharge current was decreased with water flow rate increasing, when

the flow rate was below 600 μ l/min. This is because of that needlepoint was surrounded by water in the smaller flow rate. The bigger the water flow rate is, the larger the curvature radius of point electrode is. Increased curvature radius of discharge electrode could decrease the corona discharge current. When water flow rate was above 600 μ l/min, the discharge current was enhanced with water flow rate increasing. The reason was that point electrode would prolong as a short wire electrode above 600 μ l/min flow rate. The longer wire electrode had greater discharge current.

The mechanisms of both precipitation and gas purifying between water-point and plate electrodes are the same as in the above-mentioned wet spraying corona discharges. The spraying mechanism is varied from semi-wet spraying corona discharges. When water flow rate was under 600 μ l/min, the discharge electrode is a metal point electrode covered with a water layer. The water sputtering produced by positive ions would be dominant. When water flow rate was above 600 μ l/min, the water point electrode prolonged as a water wire electrode. The spraying mechanism of EHD would play a most important role.

4 Conclusions

The advantages of spraying corona discharges with grounding discharge electrodes for purifying flue-gas were listed as follows.

(1) In the spraying corona discharges, both the discharge electrodes and supplying water system are grounded. Therefore the difficulty of HV insulation in the supplying water system is avoided and the stable and safe operation of the precipitators is insured.

(2) The water spraying is continual on the surface of discharge electrodes and the cleaning of the electrodes is kept.

(3) The water sprays cross the non-thermal plasma region near the water surface. The treated sprays contain some active species, such as O₃, H₂O₂ and so on.

(4) The water sprays cross the near corona region and are efficiently charged by high-concentration free electrons and negative ions.

(5) The sprays with a large number of charges and active species distribute evenly in the most of interelectrode region. The boundary surfaces between sprays and flue gas are highly enlarged. On the one hand the agglomeration of sprays and dusts is greatly increased, on the other hand the removal function of harmful gases is possible.

(6) Sprays along with dusts run into the collecting plate electrodes. Both the back corona of high resistivity dusts and the bounce of low resistivity dusts can be avoided.

(7) In the precipitation of wet spraying corona discharges, a thin and flowing down water layer is formed on the collecting electrodes and effectively clean the electrodes. In the precipitation of semi-wet spraying corona discharges, a little spray can increase the flowage of liquid contamination or properly raise the moisture content of dust layer on the collecting electrodes, which benefit the cleaning of the electrode.

(8) In the precipitation of wet spraying corona discharges, the circulation water is repeatedly treated by corona plasma near the discharge electrodes. The circulation water can be employed for a long time and sewage can be greatly cut down.

(9) In the precipitation of wet spraying corona discharges, the water layer on the electrodes is a good electric conductor. It is possible to make the electrodes using insulation material and avoided the corrosion of the electrodes.

(10) The size analysis of the spraying corona discharges demonstrates the almost all the sprays have the sizes over 80 μ m diameter. The sprays are easily captured and cannot pollute the atmosphere.

References

- [1] C. W. Lear, W. F. Krieve and E. Cohen, "Charged droplet scrubbing for fine particle control", J. of Air Pollution Association, **25**(2), (1975): 184-189
- [2] Dexuan Xu, Jie Li, Yan Wu, Linhui Wang, Dawei Sun, Zhongyang Liu, Yanbin Zhang. Discharge

- characteristics and applications for electrostatic precipitation of DC corona with spraying discharge electrodes, *J. of Electrostatics* **57** (2003): 217-224
- [3] Xu Dexuan, Zhao Jianwei, Ding Yunzheng, Ge Weili. Removal of adhesive dusts from flue gas using corona discharges with spraying water, *J. of Environmental Science* **15** (2003): 561-5681
- [4] Zhang Diguang and Xu Dexuan, Analysis of the current for a negative point-to-plane corona discharge in air, *J. of Electrostatics*, **25** (1990): 221
- [5] Xu Dexuan, The electrons, ions and electric field between electrodes in negative corona discharges Proc. of 3rd Int. Conf. on Applied Electrostatics, Shanghai, (1997): p 50
- [6] Kazimierz Adamiak, Anatol Jaworek and Andrzej Krupa. Deposition efficiency of dust particles on a single, falling and charged water droplet [J], *IEEE Trans. IA*, **37** (2001): 743
- [7] Lee Hee-kyu. Electric sterilization of Escherichia Coli by electrostatic atomization [J], *J. of Electrostatics*, **51-52** (2001): 71
- [8] Tomio Fujii, Yukio Aoki, Naoki Yoshioka and Massimo Rea, Removal of NO_x by DC corona reactor with water [J], *J. of Electrostatics*, **51-52**(2001): 8